

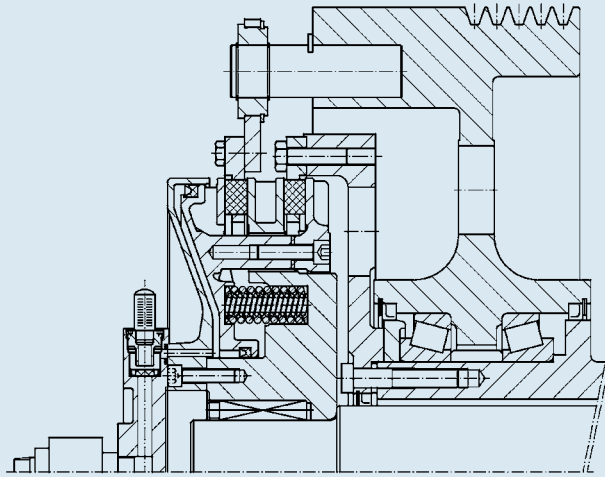

SPECIAL CLUTCH-BRAKE UNITS

FRENO-EMBRAGUES ESPECIALES

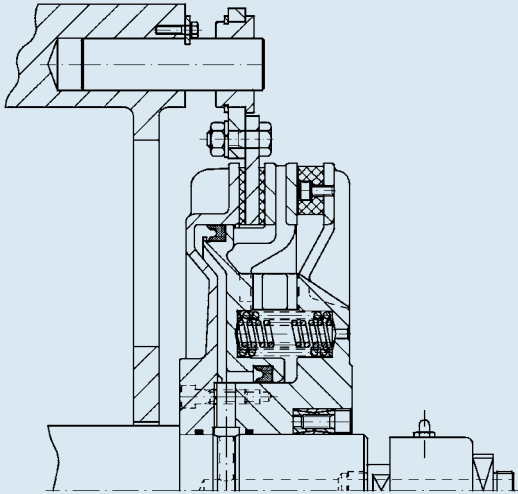

Only brake version. It is in fact a safety pneumatic brake.

Versión solo freno. Es en realidad un freno neumático de seguridad.

Clutch-brake unit with quick exhaust. To get very quick braking response time.

Freno-embrague con escape rápido. Se consiguen tiempos de respuesta en frenada considerablemente bajos.

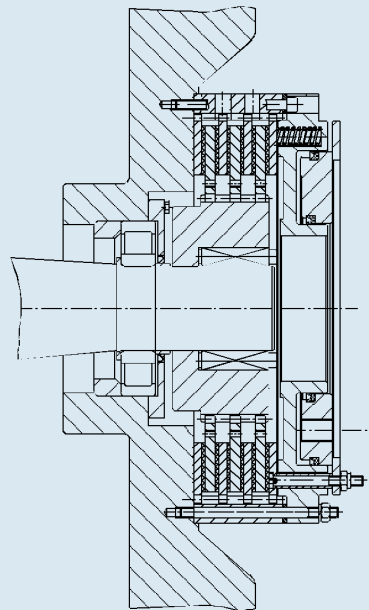
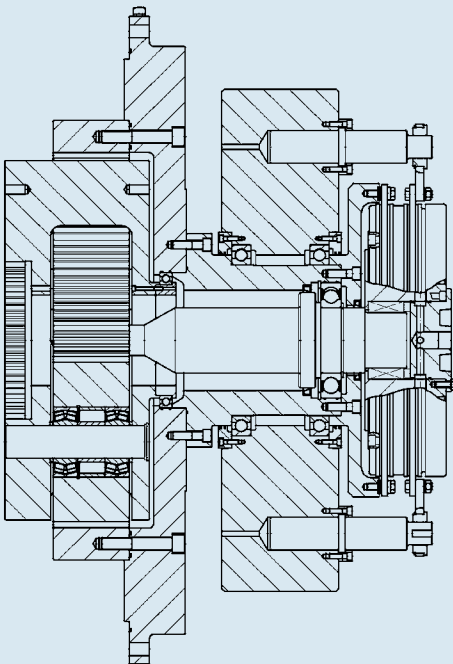

Clutch-brake with planetary gear.
Freno-embrague con reductor planetario.

Pneumatic safety brake.
Freno neumático de seguridad.

FOR DRAWINGS, SPECIFICATIONS AND QUESTIONS REGARDING A GOIZPER PRODUCT, PLEASE CONTACT US:
Toll-Free: 1-800-813-0844 | Phone: 1-941-358-9447 | Fax: 1-941-358-9647 | Web: www.goizperusa.com | Email: sales@goizperusa.com



Torque Technologies, the exclusive U.S. stocking agency of GOIZPER Clutches, Brakes and Clutch-Brakes provides expert, computerized application engineering and retrofit services to customers across the USA.