

Series 5.35

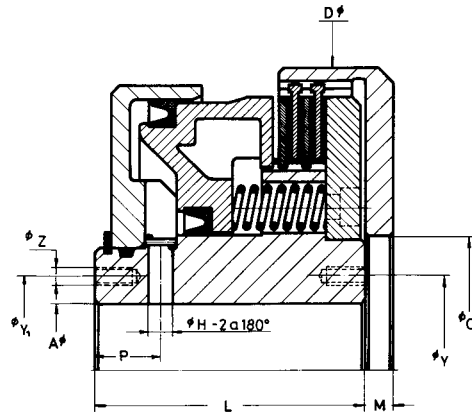

PNEUMATICALLY ACTUATED MULTI DISC CLUTCHES  
EMBRAGUES NEUMÁTICOS MULTIDISCO

Series		5.35											
Size		16	32	64	90	12	18	36	55	75	76	77	81
Torque	Nm	160	320	640	900	1.280	1.800	3.600	5.500	7.500	10.000	15.000	22.000
Pressure	Bar	5,5											
Speed max.	min-1	3.500	3.500	2.800	2.100	2.000	1.900	1.900	1.900	1.500	1.400	1.000	1.000
Weight	kg	10	12	20	25	32	50	56	72	85	120	300	340
J	Int	0,019	0,027	0,112	0,140	0,3	0,47	0,5	0,9	1,3	1,8	7	7,5
	Ext.	0,01	0,012	0,03	0,06	0,15	0,19	0,21	0,25	1,3	1,8	3	4
New volum.	dm <sup>3</sup>	0,06	0,08	0,12	0,20	0,35	0,70	0,70	1,30	1,40	1,40	2,30	2,50
Max. wear volum.		0,13	0,20	0,35	0,48	0,85	1,40	1,70	2,40	2,60	3	4	4,50
Ø A min.		20	25	30	30	30	50	50	70	70	70	50	100
Ø A max.		50	50	70	70	90	100	100	130	130	130	150	150
Ø C min.		50	50	85	85	100	90	120	180	180	180	200	200
Ø C max.		110	110	160	160	230	260	260	340	340	340	480	480
Ø D		165	165	225	225	295	345	345	444	444	444	600	600
Ø H		8	8	10	10	10	10	12	14	14	14	14	14
L		80	87	100	110	115	130	140	145	160	167	200	225
M		10	10	10	10	10	15	15	20	20	20	20	20
P		22	22	25	25	30	35	35	40	40	40	60	60
Ø Y <sub>1</sub>		-	-	-	-	110	120	120	146	152	152	186	186
Ø Y		60	60	80	80	110	120	120	180	180	180	210	210
Ø Z 2x180°		M6	M6	M6	M6	M12	M12	M12	M12	M12	M12	M12	M16

