

GOIZPER



GOIZPER

PGI SERIES INDEX TABLES

TABLES D'INDEXAGE SERIE PGI

220

320

420

520

FOR DRAWINGS, SPECIFICATIONS AND QUESTIONS REGARDING A GOIZPER PRODUCT, PLEASE CONTACT US:
Toll-Free: 1-800-813-0844 | Phone: 1-941-358-9447 | Fax: 1-941-358-9647 | Web: www.goizperusa.com | Email: sales@goizperusa.com



Torque Technologies, the exclusive U.S. stocking agency of GOIZPER Clutches, Brakes and Clutch-Brakes provides expert, computerized application engineering and retrofit services to customers across the USA.



PGI 220

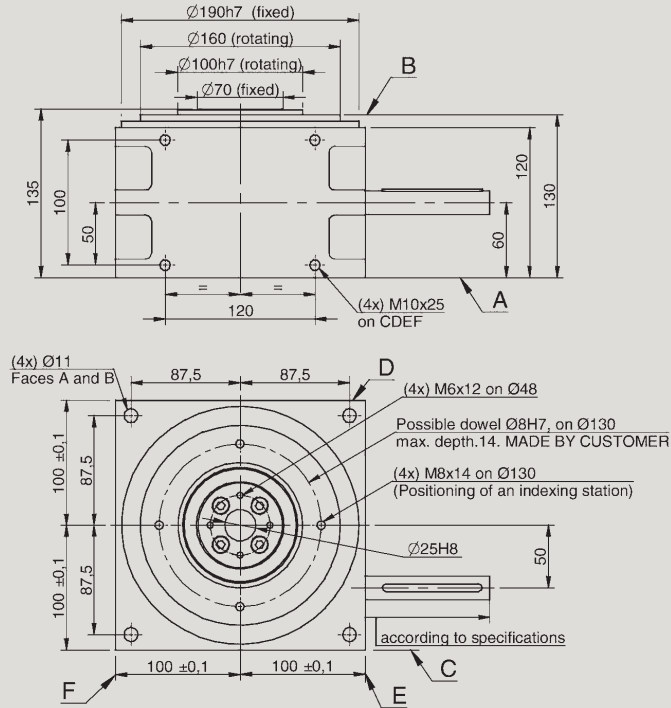

PGI 320

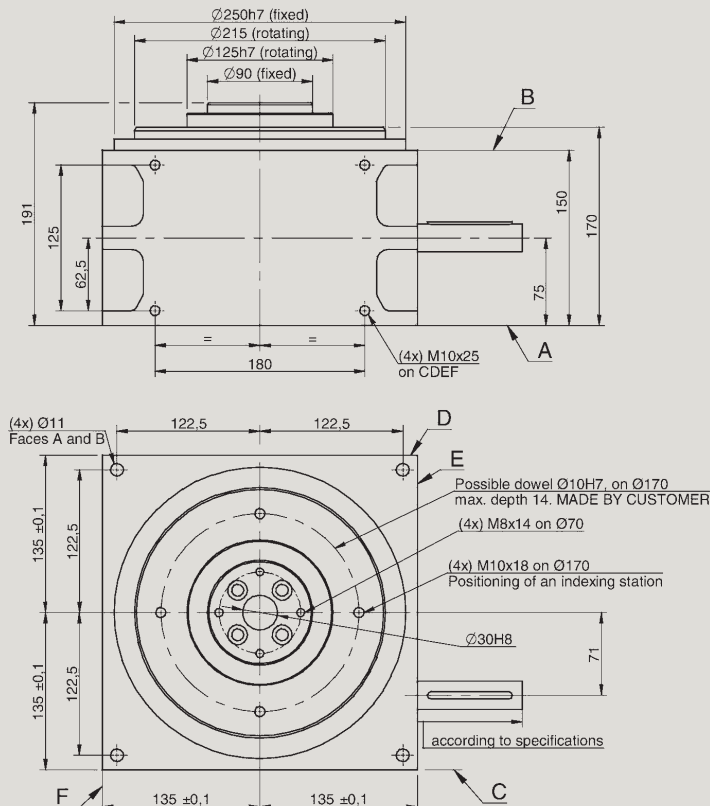

Technical Characteristics Caractéristiques techniques

Repeatability <i>Répétabilité</i>	± 0,015 on/sur Ø 160
Indexing accuracy <i>Précision d'indexage</i>	± 0,030 on/sur Ø 160
Maximum allowable axial load <i>Charge axiale max. admissible</i>	6.750 N
Maximum allowable tilting torque <i>Couple de basculement max. admissible</i>	265 Nm
Maximum allowable radial load <i>Charge radiale max. admissible</i>	2.300 N
Weight with moto reducer <i>Poids de l'indexeur motorisé</i>	~ 35 kg

Technical Characteristics Caractéristiques techniques

Repeatability <i>Répétabilité</i>	± 0,014 on/sur Ø 215
Indexing accuracy <i>Précision d'indexage</i>	± 0,028 on/sur Ø 215
Maximum allowable axial load <i>Charge axiale max. admissible</i>	9.000 N
Maximum allowable tilting torque <i>Couple de basculement max. admissible</i>	320 Nm
Maximum allowable radial load <i>Charge radiale max. admissible</i>	3.200 N
Weight with moto reducer <i>Poids de l'indexeur motorisé</i>	~ 65 kg

FOR DRAWINGS, SPECIFICATIONS AND QUESTIONS REGARDING A GOIZPER PRODUCT, PLEASE CONTACT US:
Toll-Free: 1-800-813-0844 | Phone: 1-941-358-9447 | Fax: 1-941-358-9647 | Web: www.goizperusa.com | Email: sales@goizperusa.com



Torque Technologies, the exclusive U.S. stocking agency of GOIZPER Clutches, Brakes and Clutch-Brakes provides expert, computerized application engineering and retrofit services to customers across the USA.



PGI 420

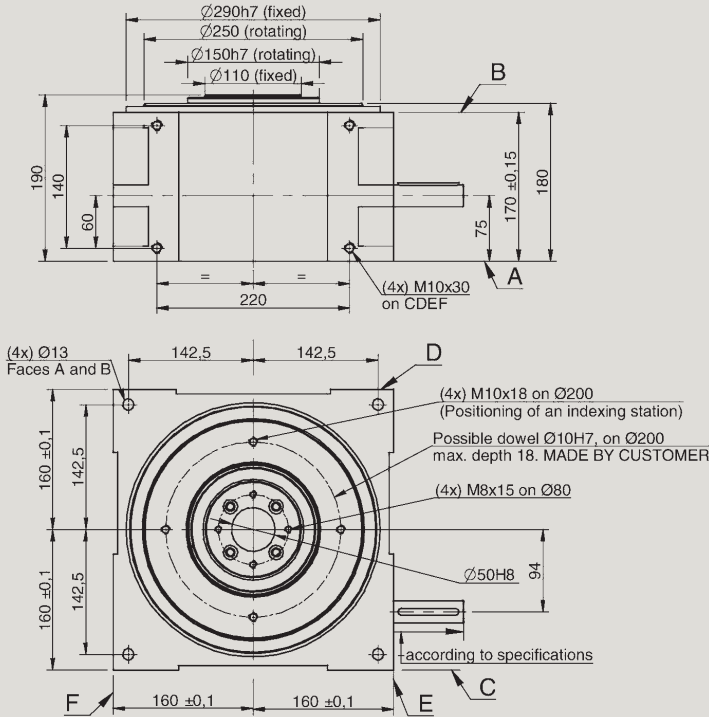

Technical Characteristics Caractéristiques techniques

Repeatability <i>Répétabilité</i>	± 0,012 on/sur Ø 250
Indexing accuracy <i>Précision d'indexage</i>	± 0,025 on/sur Ø 250
Maximum allowable axial load <i>Charge axiale max. admissible</i>	13.800 N
Maximum allowable tilting torque <i>Couple de basculement max. admissible</i>	1.100 Nm
Maximum allowable radial load <i>Charge radiale max. admissible</i>	4.600 N
Weight with moto reducer <i>Poids de l'indexeur motorisé</i>	~ 100 kg

PGI 520

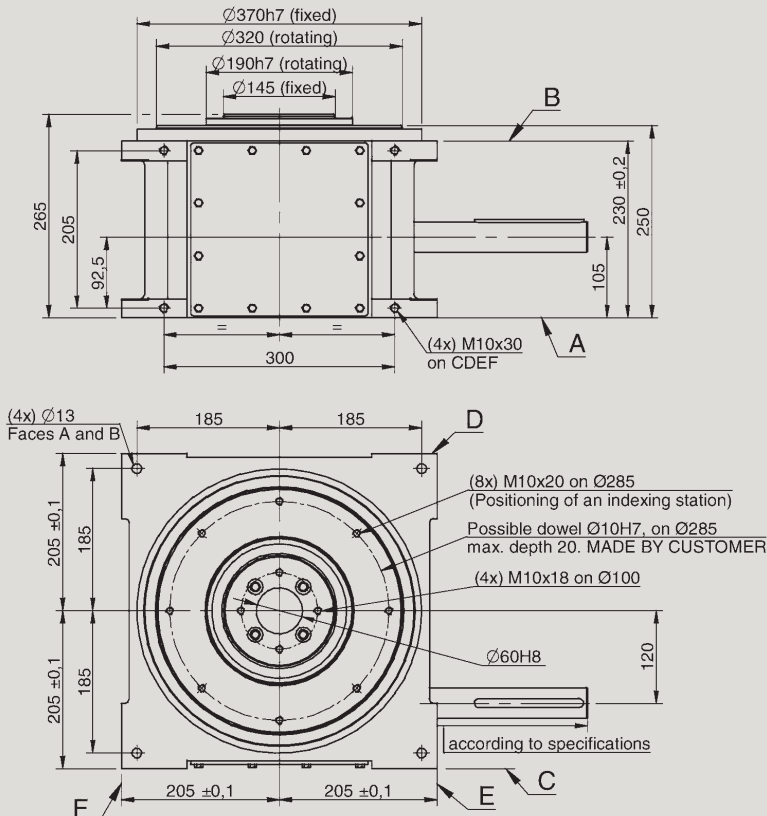

Technical Characteristics Caractéristiques techniques

Repeatability <i>Répétabilité</i>	± 0,012 on/sur Ø 320
Indexing accuracy <i>Précision d'indexage</i>	± 0,025 on/sur Ø 320
Maximum allowable axial load <i>Charge axiale max. admissible</i>	19.000 N
Maximum allowable tilting torque <i>Couple de basculement max. admissible</i>	1.900 Nm
Maximum allowable radial load <i>Charge radiale max. admissible</i>	9.000 N
Weight with moto reducer <i>Poids de l'indexeur motorisé</i>	~ 140 kg

FOR DRAWINGS, SPECIFICATIONS AND QUESTIONS REGARDING A GOIZPER PRODUCT, PLEASE CONTACT US:
Toll-Free: 1-800-813-0844 | Phone: 1-941-358-9447 | Fax: 1-941-358-9647 | Web: www.goizperusa.com | Email: sales@goizperusa.com



Torque Technologies, the exclusive U.S. stocking agency of GOIZPER Clutches, Brakes and Clutch-Brakes provides expert, computerized application engineering and retrofit services to customers across the USA.