

CLUTCH-BRAKES SERIES 5.8

FRENO-EMBRAGUES SERIE 5.8

This series corresponds to the latest of the pneumatic clutch-brakes developed by GOIZPER.

One of its main characteristics is that it obtains the maximum possible torque within the dimensions of the unit, due to the fact that the piston reaches the maximum diameter.

These clutch-brakes may be mounted with locking rings or keyways.

Esta serie corresponde al último de los frenoembragues neumáticos desarrollados por GOIZPER.

Entre sus características principales, destaca que se consigue el máximo par posible dentro de las medidas de la unidad, gracias a que el pistón alcanza el diámetro máximo.

Estos freno-embragues están preparados para ser montados con anillos de fijación o con chavetas.

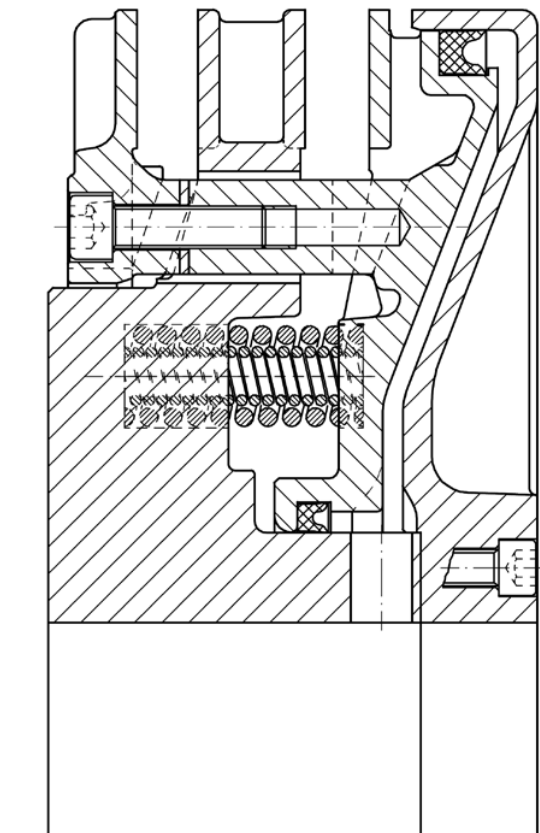

Series 5.81.*.WD

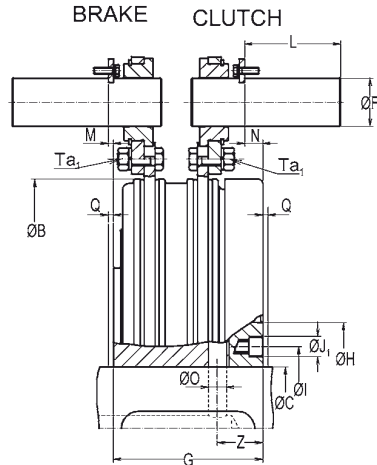
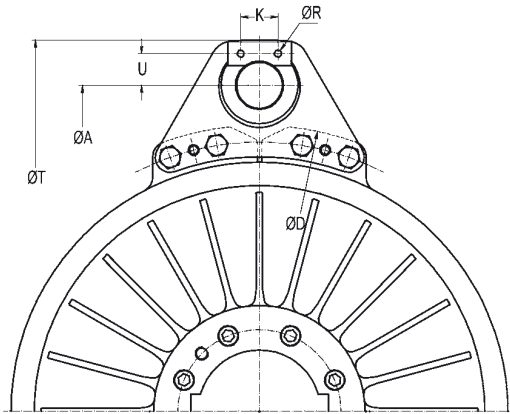

Series 5.82.*.WD

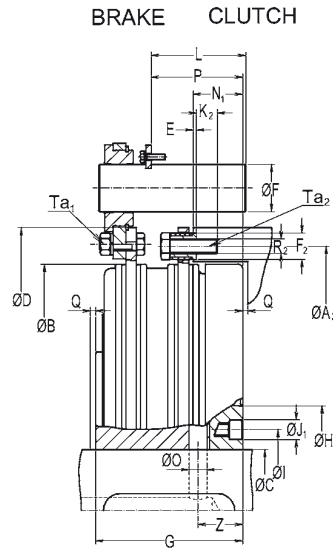
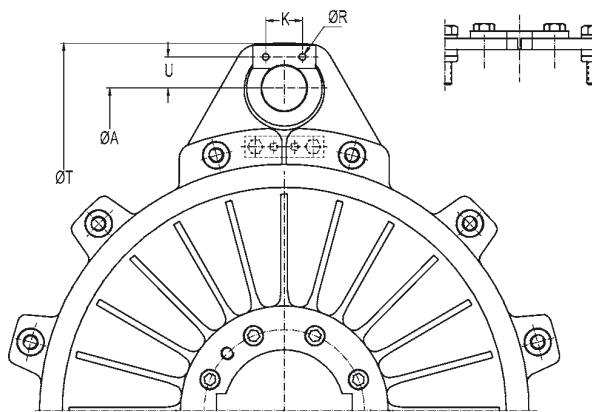

Series 5.84.*.WD

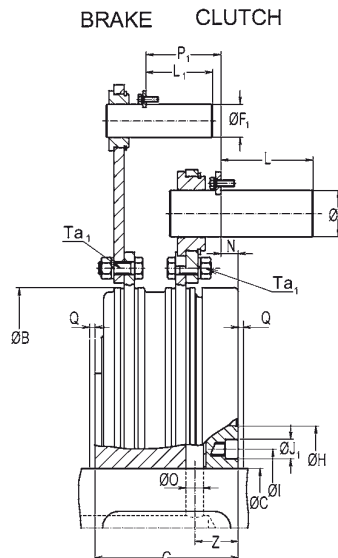
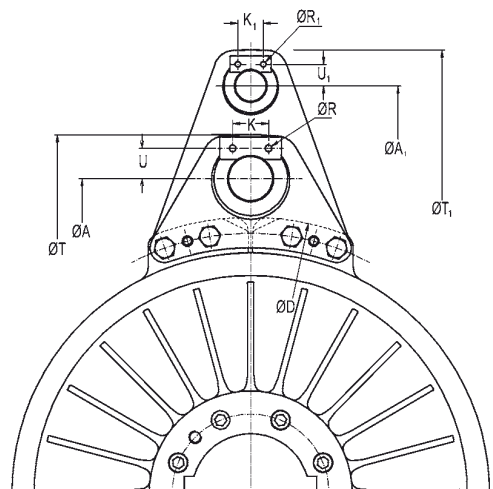

(*) Space to indicate the size
 (*) Espacio para indicar el tamaño

PNEUMATIC CLUTCH-BRAKES / FRENO-EMBRAGUES NEUMÁTICOS

SERIES		5.81.__.WD / 5.82.__.WD / 5.84.__.WD										
SIZE		23	50	10	18	36	55	75	76	77	78	80
Clutch torque	Nm	480	940	2000	4000	7550	11900	15500	22900	32000	42800	56600
Brake torque		345	665	1450	2850	5390	8500	11200	16300	22850	30500	38500
Pressure	bar	5,5										
Max speed	min ⁻¹	2750	2250	1750	1500	1250	1100	1000	850	750	700	630
581 WD	Kg	9.2	15.5	32	60	112	170	228	325	453	655	820
Weight 582 WD		9	15	30	58	106	163	220	313	437	615	774
584 WD		9.2	15.5	32	60	112	170	228	325	453	655	820
J. int.	Kg m ²	0.026	0.07	0.25	0.72	1.85	4.24	6.6	12.2	21.1	31.5	51.4
J. ext.	Kg m ²	0.013	0.04	0.1	0.283	0.953	1.546	2.91	4.97	8.82	20	27.3
J. ext.		0.008	0.027	0.062	0.202	0.615	1.031	1.55	3.34	6.51	10.5	12.8
J. ext.		0.013	0.04	0.1	0.283	0.953	1.546	2.91	4.97	8.82	20	27.3
New vol	dm ³	0.093	0.164	0.320	0.671	1.18	1.75	2.23	3.21	4.88	6.42	8.38
Max. wear Volum.		0.148	0.250	0.524	1.038	1.95	2.79	3.58	5.23	7.62	9.97	13.6
Ø A		250	315	390	495	610	695	770	880	970	1100	1180
Ø A1		325	410	490	635	790	885	990	1135	1235	1450	1525
Ø A2		205	255	325	408	500	584	640	725	810	890	965
Ø B		188	236	305	380	466	543	593	675	755	830	905
Ø C (H7)	Min.	28	35	45	55	70	80	90	100	115	115	135
	Max.	48	65	80	95	125	145	160	180	200	220	240
Ø D		226	275	347	435	535	620	680	775	865	950	1025
E		1.7	2	3	3	3	3	3	4	4	4	4
Ø F		15	22	30	32	45	45	60	60	65	75	80
Ø F ₁	12 x 30°	15	15	22	30	32	32	45	45	60	65	65
Ø F ₂		10	12	15	18	25	25	30	35	40	45	45
G		66	75	92	112	140	160	175	195	220	240	260
Ø H		85	105	141	168	198	224	250	294	324	354	390
Ø I		60	79	99	118	153	176	194	221	246	270	305
Ø J ₁		9.5	11	13.5	16.5	19	19	23	25	28	33	33
K ₁		20	25	25	25	35	35	45	45	45	60	60
K ₂		20	20	25	25	25	25	35	35	45	45	45
K ₃		7.5	11	13	16	20	20	25	38	43	36	36
L		30	45	60	65	90	90	120	120	130	150	160
L ₁		30	30	45	60	65	65	90	90	120	130	130
M		3	4	4	5	5	5	5	5	5	20	15
N		7.5	8	10.5	13	17	22	24	26	28	17	28
N ₁		22	25.5	31.5	38	47	55	61	66	75	81	90
Ø O ₁	2 x 180°	6	8	10	14	17	20	22	25	28	30	35
P		38	40	54	69	87	102	110	125	136	141.5	157
P ₁		32	38.5	45	58	73	84	86	100	114	121.5	132
Q _(*)		3	4	4	5	5	5	5	5	5	5	5
Ø R	12 x 30°	4.5	5.5	5.5	5.5	6.5	6.5	8.5	8.5	8.5	10.5	10.5
Ø R ₁		4.5	4.5	5.5	5.5	5.5	5.5	6.5	6.5	8.5	8.5	8.5
Ø R ₂		M5	M6	M8	M10	M14	M14	M16	M20	M24	M24	M24
Ø T		284	360	446	565	695	785	880	1000	1110	1260	13340
Ø T ₁		359	444	535	691	860	955	1075	1220	1345	1595	1670
Ø U		11	16	20	21	29.5	29.5	41	41	43.5	52.5	55
Ø U ₁		11	11	16	20	21	21	29.5	29.5	41	43.5	43.5
Z		17	22	28	36	42.5	51	55	62.5	71	78	86
Ta ₁	Nm	6,6	11	27,5	54	95	148	230	230	450	780	780
Ta ₂		6	10	25	49	135	135	210	410	710	710	710

(*) Space required for installation
 (*) Espacio libre requerido



Series 5.85.*.WD

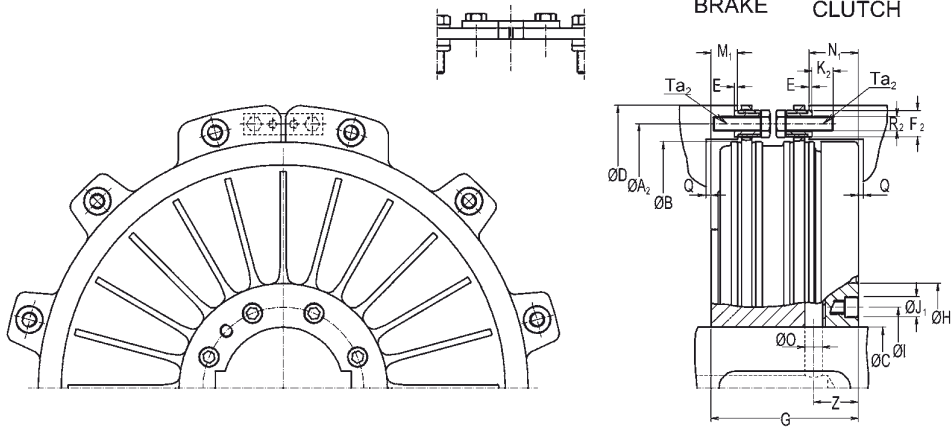

Series 5.85.*.WA

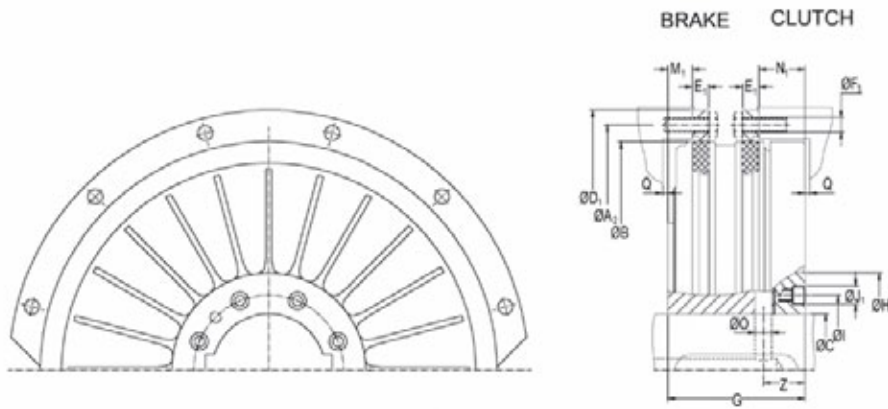

Series 5.86.*.WD

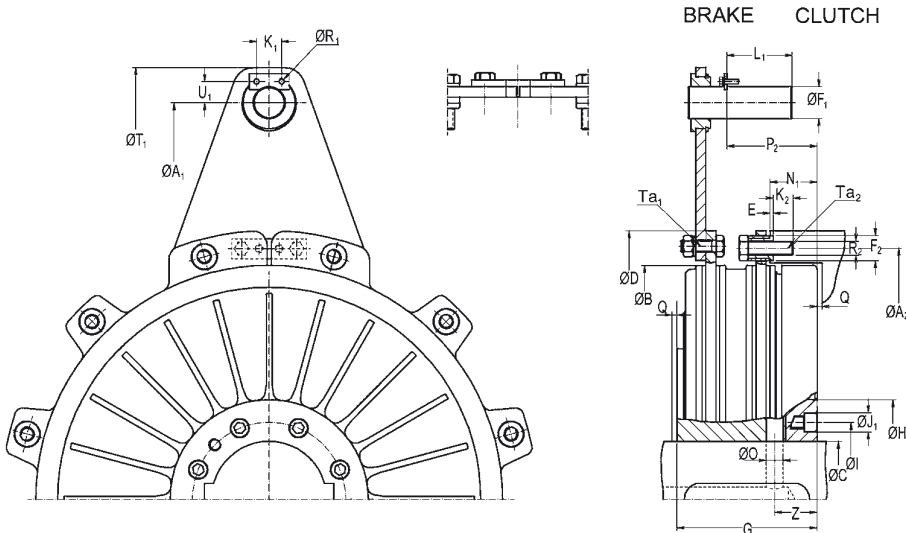

(*) Space to indicate the size

(*) Espacio para indicar el tamaño

PNEUMATIC CLUTCH-BRAKES / FRENO-EMBRAGUES NEUMÁTICOS

SERIES		5.85.__.WD / 5.85.__.WA / 5.86.__.WD										
SIZE		23	50	10	18	36	55	75	76	77	78	80
Clutch torque	Nm	480	940	2000	4000	7550	11900	15500	22900	32000	42800	56600
Brake torque		345	665	1450	2850	5390	8500	11200	16300	22850	30500	38500
Pressure	bar	5,5										
Max speed	min ⁻¹	2750	2250	1750	1500	1250	1100	1000	850	750	700	630
585 WD	Kg	9	14	29	60	100	157	210	300	421	575	728
Weight 585 WA		8.5	15	30	56	103	161	211	306	424	555	723
586 WD		9.2	15	30	58	105	162	218	311	438	615	775
J. int.	Kg m ²	0.026	0.07	0.25	0.72	1.85	4.24	6.6	12.2	21.1	31.5	51.4
J. ext. 585 WD	Kg m ²	0.008	0.027	0.062	0.202	0.615	1.031	1.55	3.34	6.51	10.5	12.8
J. ext. 585 WA		0.008	0.020	0.057	0.170	0.535	1.047	1.50	3	5.33	9.2	12.6
J. ext. 586 WD		0.008	0.027	0.062	0.202	0.615	1.031	1.55	3.34	6.51	10.5	12.8
New vol	dm ³	0.093	0.164	0.320	0.671	1.18	1.75	2.23	3.21	4.88	6.42	8.38
Max. wear Volum.		0.148	0.250	0.524	1.038	1.95	2.79	3.58	5.23	7.62	9.97	13.6
Ø A1		325	410	490	635	790	885	990	1135	1235	1450	1525
Ø A2		205	255	325	408	500	584	640	725	810	890	965
Ø B		188	236	305	380	466	543	593	675	755	830	905
Ø C (H7)	Min.	28	35	45	55	70	80	90	100	115	115	135
	Max.	48	65	80	95	125	145	160	180	200	220	240
Ø D		226	275	347	435	535	620	680	775	865	950	1025
Ø D ₁		220	275	345	430	530	620	680	770	860	945	1020
E		1.7	2	3	3	3	3	3	4	4	4	4
E ₁		8.5	9.5	11.5	13.5	18.5	19	18.5	23	27.5	31	32.5
Ø F ₁	12 x 30°	15	15	22	30	32	32	45	45	60	65	65
Ø F ₂		10	12	15	18	25	25	30	35	40	45	45
Ø F ₃		5.5	7	8.5	10.5	15	15	17	21	25	25	25
G		66	75	92	112	140	160	175	195	220	240	260
Ø H		85	105	141	168	198	224	250	294	324	354	390
Ø I		60	79	99	118	153	176	194	221	246	270	305
Ø J ₁		9.5	11	13.5	16.5	19	19	23	25	28	33	33
K ₁		20	20	25	25	25	25	35	35	45	45	45
K ₂		7.5	11	13	16	20	20	25	38	43	36	36
L ₁		30	30	45	60	65	65	90	90	120	130	130
M ₁		11	13.5	17	20	25	28	32	35	40	44	48
N ₁		22	25.5	31.5	38	47	55	61	66	75	81	90
Ø O ₁	2 x 180°	6	8	10	14	17	20	22	25	28	30	35
P ₂		39.5	46.5	55.5	71	90	106	110	126	142	138.5	160
Q _(*)		3	4	4	5	5	5	5	5	5	5	5
Ø R ₁	12 x 30°	4.5	4.5	5.5	5.5	5.5	5.5	6.5	6.5	8.5	8.5	8.5
Ø R ₂		M5	M6	M8	M10	M14	M14	M16	M20	M24	M24	M24
Ø T ₁		359	444	535	691	860	955	1075	1220	1345	1595	1670
Ø U ₁		11	11	16	20	21	21	29.5	29.5	41	43.5	43.5
Z		17	22	28	36	42.5	51	55	62.5	71	78	86
Ta ₁	Nm	6,6	11	27,5	54	95	149	230	230	450	780	780
Ta ₂		6	10	25	49	135	135	210	410	710	710	710

(*) Space required for installation
(*) Espacio libre requerido

FOR DRAWINGS, SPECIFICATIONS AND QUESTIONS REGARDING A GOZPER PRODUCT, PLEASE CONTACT US:
Toll-Free: 1-800-813-0844 | Phone: 1-941-358-9447 | Fax: 1-941-358-9647 | Email: sales@gozperusa.com | www.gozperusa.com



Torque Technologies, the exclusive U.S. stocking agency of GOZPER Clutches, Brakes and Clutch-Brakes provides expert, computerized application engineering and retrofit services to customers across the USA.

ASSEMBLY EXAMPLES / EJEMPLOS DE MONTAJE

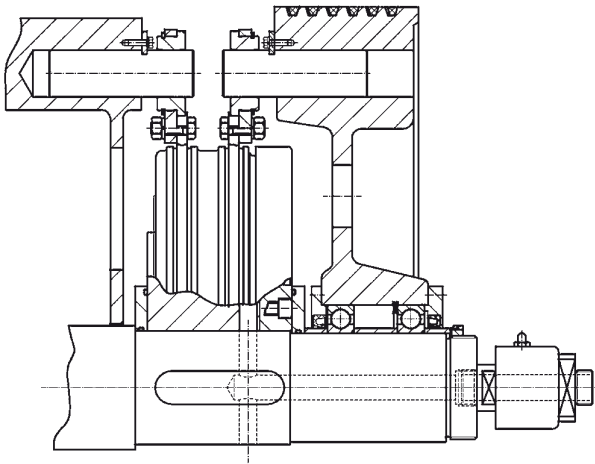

Series 5.81. __. WD

Mounting between frame and flywheel by means of identical pins on the clutch side as well as on the brake side.

Montaje entre bastidor y volante con bulones iguales en el lado embrague y lado freno.

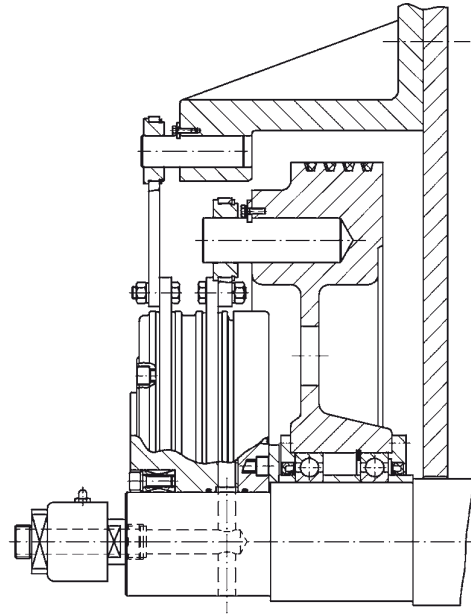

Series 5.84. __. WD

Mounting at shaft end by means of pins on different diameters on both clutch and brake side. Fixed in the shaft by locking ring.

Montaje en el extremo del eje con bulones en el lado embrague y en el lado freno situados en diametros distintos. Montado en el eje con anillo fijación.

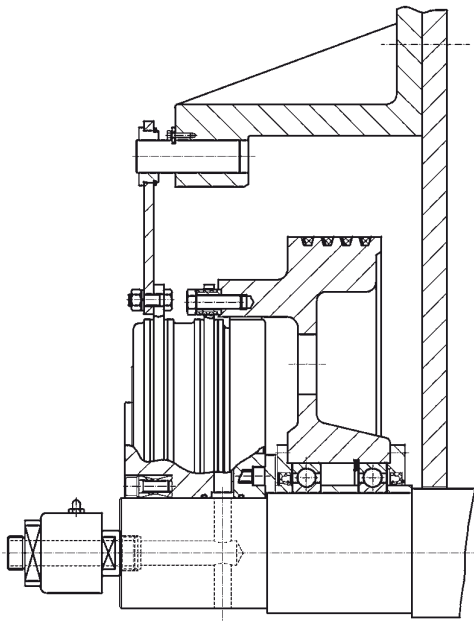

Series 5.86. __. WE

Mounting at shaft end by means of pads in clutch side and pins in brake side. Fixed on the shaft by locking ring.

Montaje en el extremo del eje con tacos en el lado embrague y bulones en el lado freno. Montado en el eje con anillo de fijación.

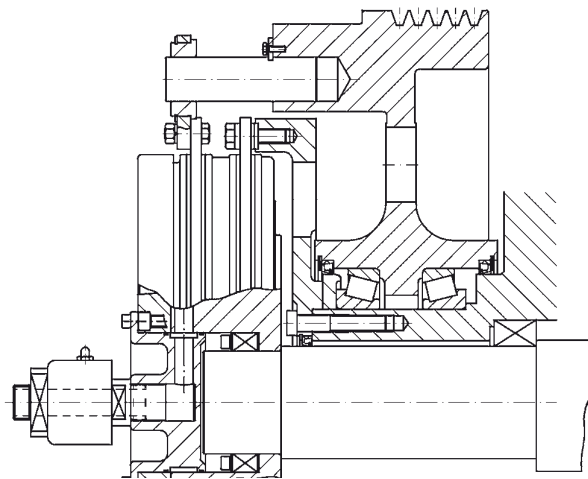

Series 5.83. __. CD

Mounting at shaft end by means of 12 bushings on the brake side and 2 pins on the clutch side. Fixed on the shaft by locking ring. Special air feeding via air inlet block.

Montaje en el extremo del eje con 12 casquillos en el lado freno y 2 bulones en el lado embrague. Montado en el eje con anillo de fijación. Alimentación de aire especial.

Torque Ratings 5.8 / Rango de Pares 5.8

SIZE	QUANTITY OF SPRINGS	BRAKE TORQUE (N.m)	CLUTCH TORQUE (N.m)	
			5,5 bar	6 bar
23	18	410	410	485
	15	345	480	560
	12	275	555	630
	9	205	625	705
	6	135	700	775
50	18 + 18	800	800	950
	15 + 15	665	940	1090
	12 + 12	535	1080	1230
	9 + 9	400	1220	1370
	6 + 6	270	1360	1510
10	18 + 18	1750	1700	2050
	15 + 15	1450	2000	2350
	12 + 12	1150	2350	2650
	9 + 9	880	2650	2950
	6 + 6	580	2950	3290
18	18 + 18	3400	3450	4050
	15 + 15	2850	4000	4650
	12 + 12	2250	4600	5250
	9 + 9	1700	5200	5850
	6 + 6	1150	5800	6450
36	18 + 18	6450	6400	7600
	15 + 15	5390	7550	8700
	12 + 12	4300	8650	9840
	9 + 9	3200	9750	10900
	6 + 6	2150	10800	12000
55	21 + 21	9950	10450	12400
	18 + 18	8500	11900	13800
	15 + 15	7100	13400	15300
	12 + 12	5700	14900	16800
	9 + 9	4250	16400	18300
75	21 + 21	13000	13600	16100
	18 + 18	11200	15500	18000
	15 + 15	9300	17500	20000
	12 + 12	7400	19400	21900
	9 + 9	5600	21400	23800
76	21 + 21	19000	20000	23700
	18 + 18	16300	22900	26500
	15 + 15	13600	25700	29300
	12 + 12	10900	28500	32200
	9 + 9	8150	31400	35000
77	21 + 21	26700	28000	33100
	18 + 18	22850	32000	37100
	15 + 15	19000	36000	41100
	12 + 12	15200	40000	45100
	9 + 9	11400	44000	49100
78	21 + 21	35600	37500	44300
	18 + 18	30500	42800	49600
	15 + 15	25400	48100	54900
	12 + 12	20300	53400	60200
	9 + 9	15200	58700	65500
80	24 + 24	44000	50800	59700
	21 + 21	38500	56600	65500
	18 + 18	33000	62500	71300
	15 + 15	27500	68300	77100

FOR DRAWINGS, SPECIFICATIONS AND QUESTIONS REGARDING A GOZPER PRODUCT, PLEASE CONTACT US:
 Toll-Free: 1-800-813-0844 | Phone: 1-941-358-9447 | Fax: 1-941-358-9647 | Email: sales@gozperusa.com | www.gozperusa.com



Torque Technologies, the exclusive U.S. stocking agency of GOZPER Clutches, Brakes and Clutch-Brakes provides expert, computerized application engineering and retrofit services to customers across the USA.